

Material

- Main body: pressed brass type CW617, nickel-plated from the outside, on surfaces, which do not have contact with water –
- full anti-diffusion barrier
- Clamping ring: stainless steel
- O-ring gasket: EPDM

Area of application

- Installations of hot & cold tap water
- Central heating (radiator connections)
- Surface heating (underfloor and wall heating installations)
- Ice water

Overview

The connection between the pipe and the fitting is obtained by pressing the pipe into the fitting's profile. The pressing should be made in the connection area, with a pressing tool equipped with U-type inserts, matched to the type of fitting used. The tightness of the connection chamber is guaranteed by two O-rings, perfectly integrated into the joint area. Pressed connections can be used in the floor groove or a wall furrow.

Dimensions

Size	L	L1	L2	L3	L4	D1	D2	D3	Code
16x25x16	82	44	26	26	32,6	11,8	11,8	19,8	06013103
16x20x16	72	37	26	26	26	11,8	11,8	15,8	06013105
16x18x16	75	37,5	26	26	26	11,8	11,8	13,8	06013106
20x16x16	72,5	38,5	26	26	26	15,8	11,8	11,8	06013107
18x16x16	73,5	37	26	26	26	13,8	11,8	11,8	06013108
20x16x20	74	38	26	26	26	15,8	15,8	11,8	06013109
18x16x18	74	37	26	26	26	13,8	13,8	11,8	06013110
20x18x20	74	38,5	26	26	26	15,8	15,8	13,8	06013111
20x20x16	77	38,5	26	26	26	15,8	11,8	15,8	06013113
20x25x20	82	46	26	26	32,6	15,8	15,8	19,8	06013115
25x16x25	84	41	32,6	32,6	26	19,8	19,8	11,8	06013117
25x18x25	87	41	32,6	32,6	26	19,8	19,8	13,8	06013119
25x20x25	90	40,5	32,6	32,6	26	19,8	19,8	15,8	06013121
25x20x20	82,2	42	32,6	26	26	19,8	15,8	15,8	06013123
25x25x20	87	47	32,6	26	32,6	19,8	15,8	19,8	06013125
25x32x25	99	47	32,6	32,6	32,6	19,8	19,8	25,8	06013127
32x16x32	86	44,5	32,6	32,6	26	25,8	25,8	11,8	06013129
32x20x32	90	44,5	32,6	32,6	26	25,8	25,8	15,8	06013131
32x25x32	96	50	32,6	32,6	32,6	25,8	25,8	19,8	06013133
40x20x40	116	50	45	45	26	31,8	31,8	15,8	06013134
40x25x40	120	55	45	45	32,6	31,8	31,8	19,8	06013135
40x32x40	128	57	45	45	32,6	31,8	31,8	25,8	06013137
50x25x50	116	61,5	45	45	32,6	40,8	40,8	19,8	06013138
50x32x50	128	60	45	45	32,6	40,8	40,8	25,8	06013139
50x40x50	136	73	45	45	45	40,8	40,8	31,8	06013141
63x32x63	168	68	68	68	32,6	50,7	50,7	25,8	06013142
63x40x63	181	79,5	68	68	45	50,7	50,7	31,8	06013143
63x50x63	191	79,5	68	68	45	50,7	50,7	40,8	06013145
75x32x75	174	75	68	68	32,6	59,6	59,6	25,8	06013148
75x40x75	183	87	68	68	45	59,6	59,6	31,8	06013146
75x50x75	194	87,5	68	68	45	59,6	59,6	40,8	06013147
75x63x75	205	109	68	68	68	59,6	59,6	50,7	06013149

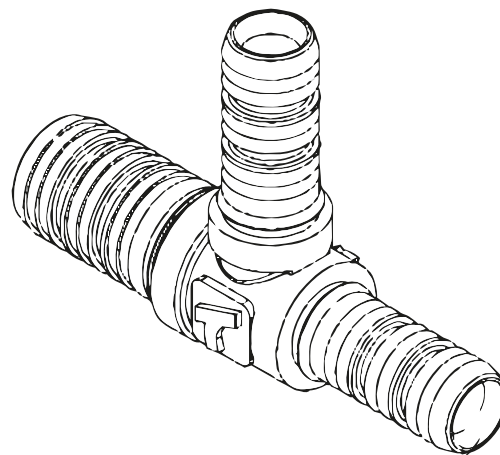
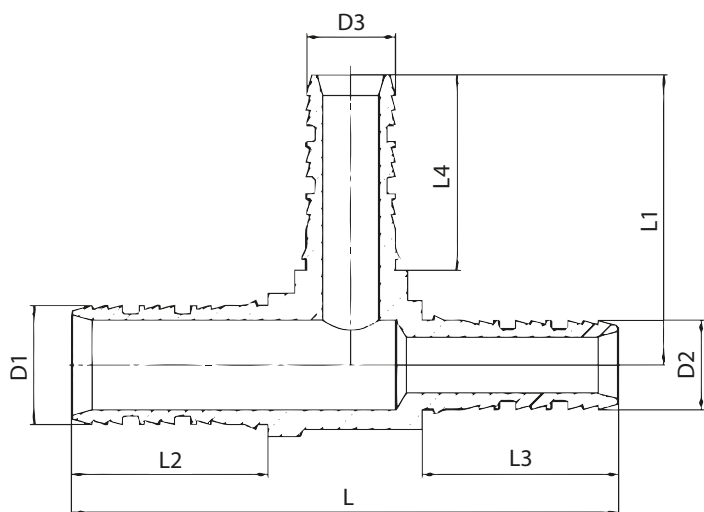

Tweetop sp. z o.o.
Ludowa 24c | 71-700 Szczecin

Scope of delivery

Main body with sealing and clamping rings